

L = MM				
9.30	10.00	10.50		

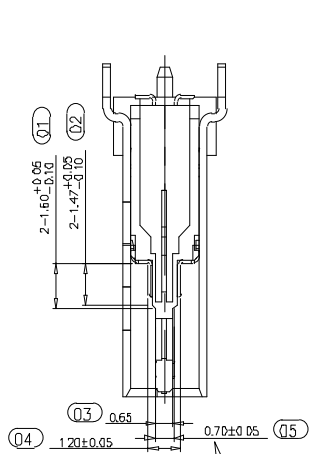

SECTION A-A
SCALE 1:1

舌片厚度

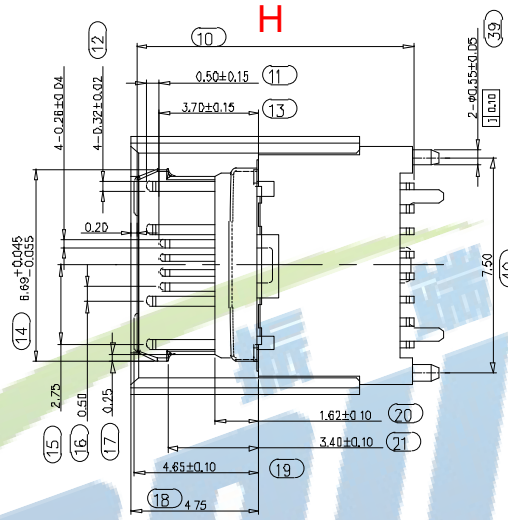
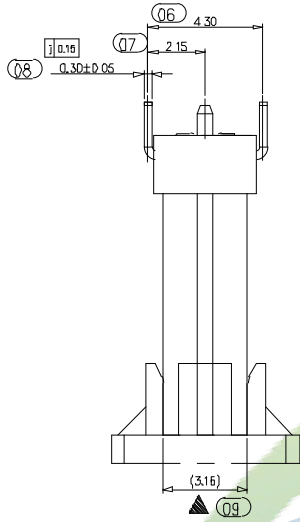

SECTION B-B
SCALE 1:1

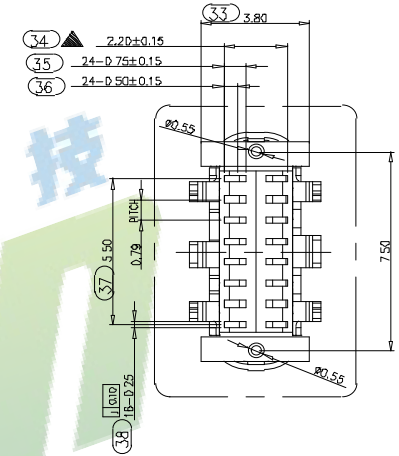

备注:

- 1, 材质: 外壳: SUS304 1/2H T=D 30±0.01mm;
护套: SUS316L 140~160 T=0.10±0.01mm;
端子 C7025 T=0.12±0.01mm;
胶芯: 热塑性塑胶CP, 黑色.
中夹片, SUS304 H T=0.15±0.01mm;
- 2, 电镀: 外壳: 全表面镀锌100u" Min.
端子: 镀底80~100u", 镀雾锡100~120u" Min.
- 3, 外观不允许有压伤, 脏污, 划痕, 错位等现象;
- 4, 盐雾测试需过24H以上,
- 5, 连接处错位0.03mmMax, 不能有变形,
- 6, 有"CPK"标志的需制程稳定控制,
- 7, 有" "标志的尺寸为QIP检验尺寸,
- 8, 有" "标志的尺寸为FAI检验尺寸,
- 9, 产品符合USB 协会标准,

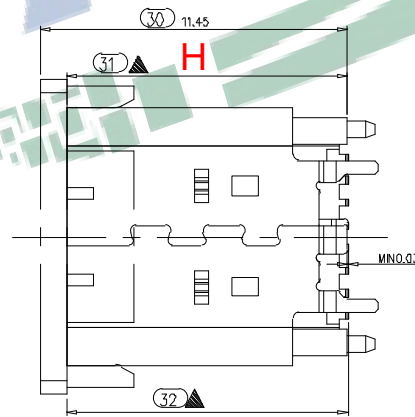
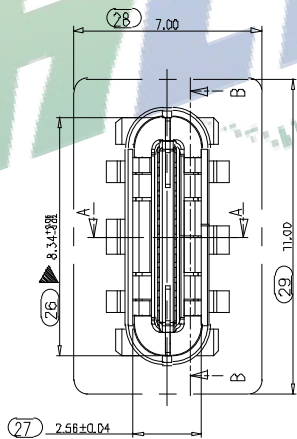
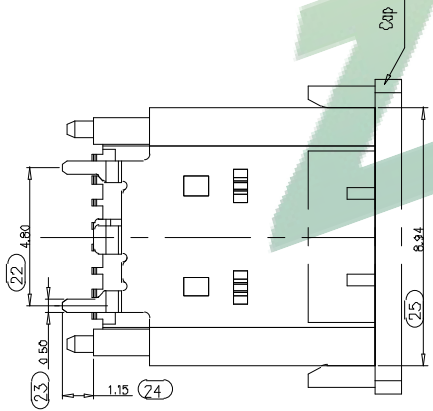

振端精密科技 (深圳) 有限公司 Zhenduan precision technology (Shenzhen) Co., Ltd			
TOLERANCE: X.X ±0.30 X.XX ±0.20 X.XXX ±0.10 X.XX ±0.10 X.X ±0.05 X.X ±0.05	DRAWN BY : 刘志强	DATE : 2015.08.18	PART NAME: TYPE-C16PIN立式贴板H9.3-10.5
UNIT: mm [inch] SCALE: 1:1 SIZE: A4	CHECKED BY: 李毅	DATE : 2015.08.18	PART NO. SEE TABLE MOLD NO.
	APPROVED BY: 张少辉	DATE : 2015.08.18	DRAW NO: ZDJNKJ00001615 SHEET NO. 1 OF 1

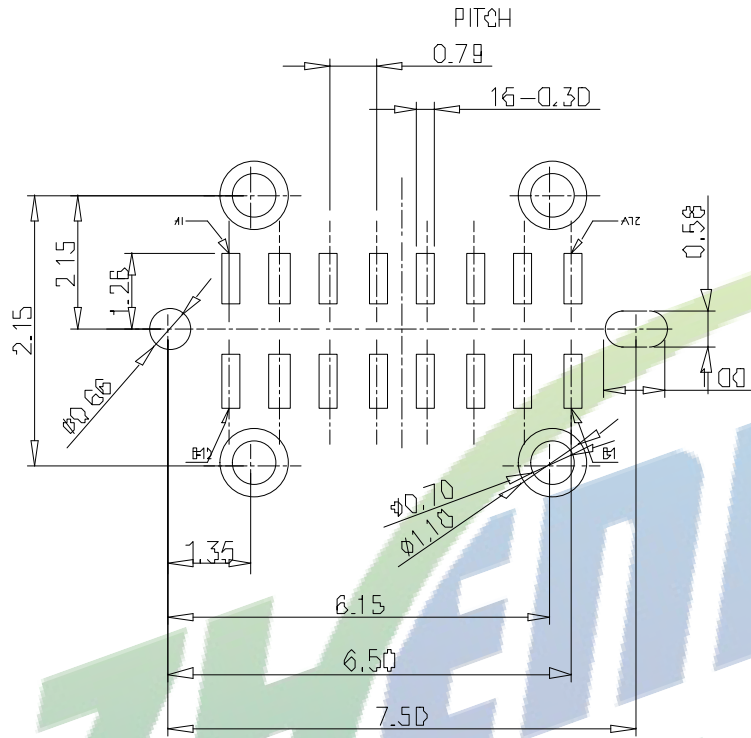

USB TYPE-C FULL-FEATURED RECEPTACLE INTERFACE PIN ASSIGNMENTS

PIN	Signal Name	Description	PIN	Signal Name	Description
A1	GND	Ground return	B12	GND	Ground return
A4	Vbus	Bus Power	B9	Vbus	Bus Power
A5	CC1	Configuration Channel	B8	SBU2	Sideband Use (SBU)
A6	Dp1	Positive half of the USB 2.0 differential pair-Position 1	B7	Dn2	Negative half of the USB 2.0 differential pair-Position 2
A7	Dn1	Negative half of the USB 2.0 differential pair-Position 1	B6	Dp2	Positive half of the USB 2.0 differential pair-Position 2
A8	SBU1	Sideband Use(SBU)	B5	CC2	Configuration Channel
A9	Vbus	Bus Power	B4	Vbus	Bus Power
A12	GND	Ground return	B1	GND	Ground return

RECOMMENDED P.C.B. LAYOUT (T:1.00mm)

TOLERANCE UNSPECIFIED ±0.05mm

SCALE: 1:1

zhenduan 振端精密科技 (深圳) 有限公司
Zhenduan precision technology (Shenzhen) Co., Ltd

TOLERANCE: X.XX ±0.30 X.XXX ±0.20 X.XXX ±0.10 X.XX ±0.10 X.XX ±0.05 X.XX ±0.05	DRAWN BY:	DATE:	PART NAME:	
	刘志强	2015.08.18	TYPE-C16PIN立式贴板H9.3-10.5	
UNIT: mm [inch] SCALE:1:1 SIZE: A4	CHECKED BY:	DATE:	PART NO.	SEE TABLE
	李毅	2015.08.18	MOLD NO.	
	APPROVED BY:	DATE:	DRAW NO.:	ZDJNKJ00001615
	张少辉	2015.08.18	SHEET NO.:	1 OF 1

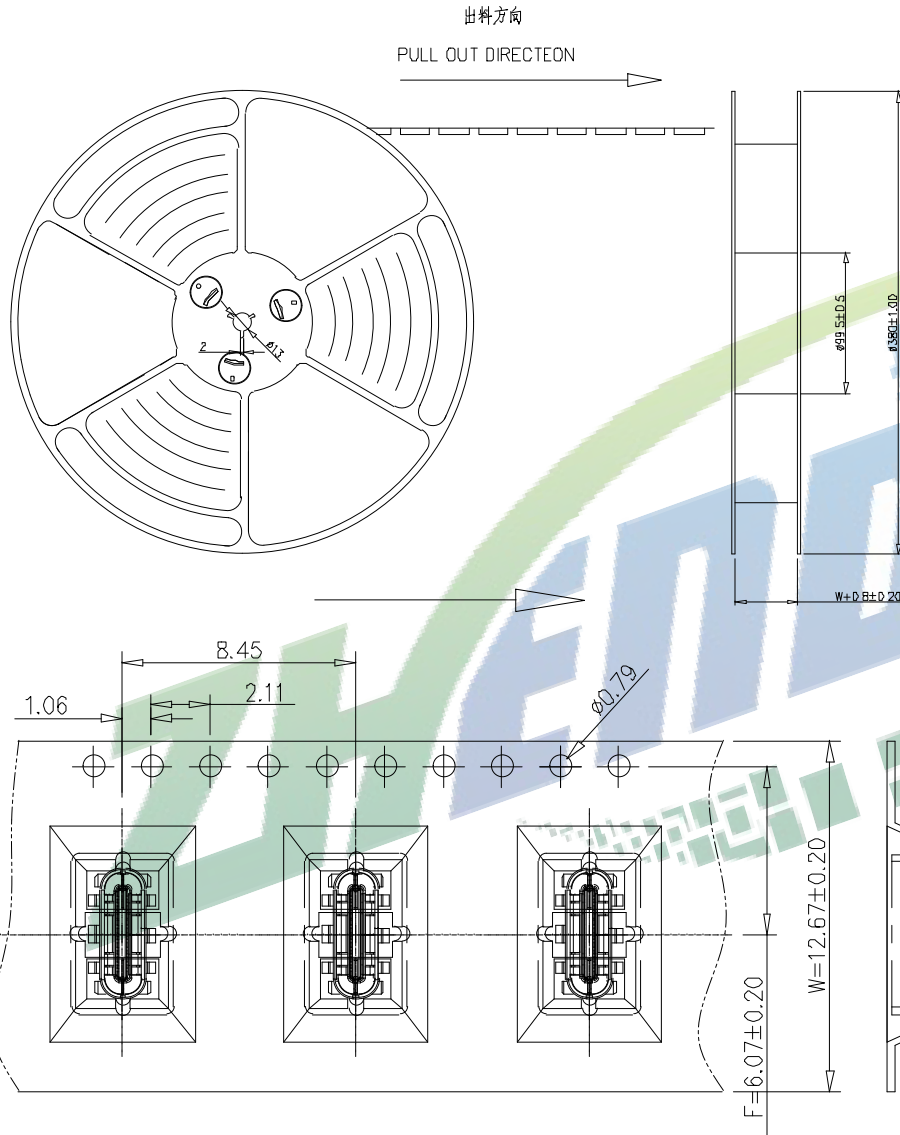

NOTES

- 1. 子引 度
LEAD TAPE LENGTH
出料方向
PULL OUT DIRECTION

- 2. 出 程中一定注意:
THIS REQUIREMENT SHOULD BE APPLIED AT SHIPMENT:
若在 卷中不能做
PEELING OFF SHOULD NOT BE ALLOWED DURING TRANSPORTATION

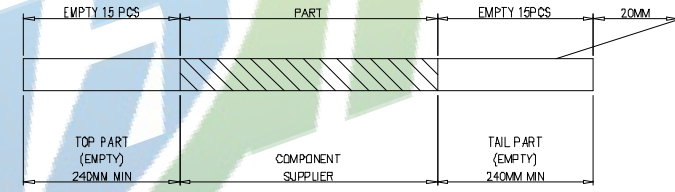

振端精密科技 (深圳) 有限公司 Zhenduan precision technology (Shenzhen) Co., Ltd			
TOLERANCE: X.X ±0.30 X.XX ±0.20 X.XXX ±0.10 X.XX ±.10 X.X ±.05 X.X ±.02	DRAWN BY : 刘志强	DATE : 2015.08.18	PART NAME: TYPE-C16PIN立式贴板H9.3-10.5
UNIT: mm [inch] SCALE: 1:1 SIZE: A4	CHECKED BY: 李毅	DATE : 2015.08.18	PART NO. SEE TABLE MOLD NO.
	APPROVED BY: 张少辉	DATE : 2015.08.18	DRAW NO.: ZDJNKJ00001615 SHEET NO. 1 OF 1

at small positioning hole of the carrier tape side).

※ (朝 包材的小定位孔一)

Location of label sticking (label

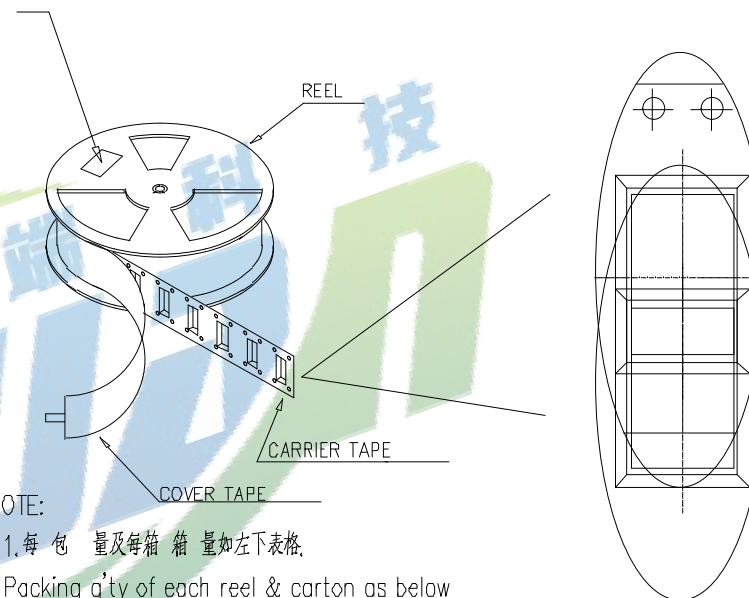
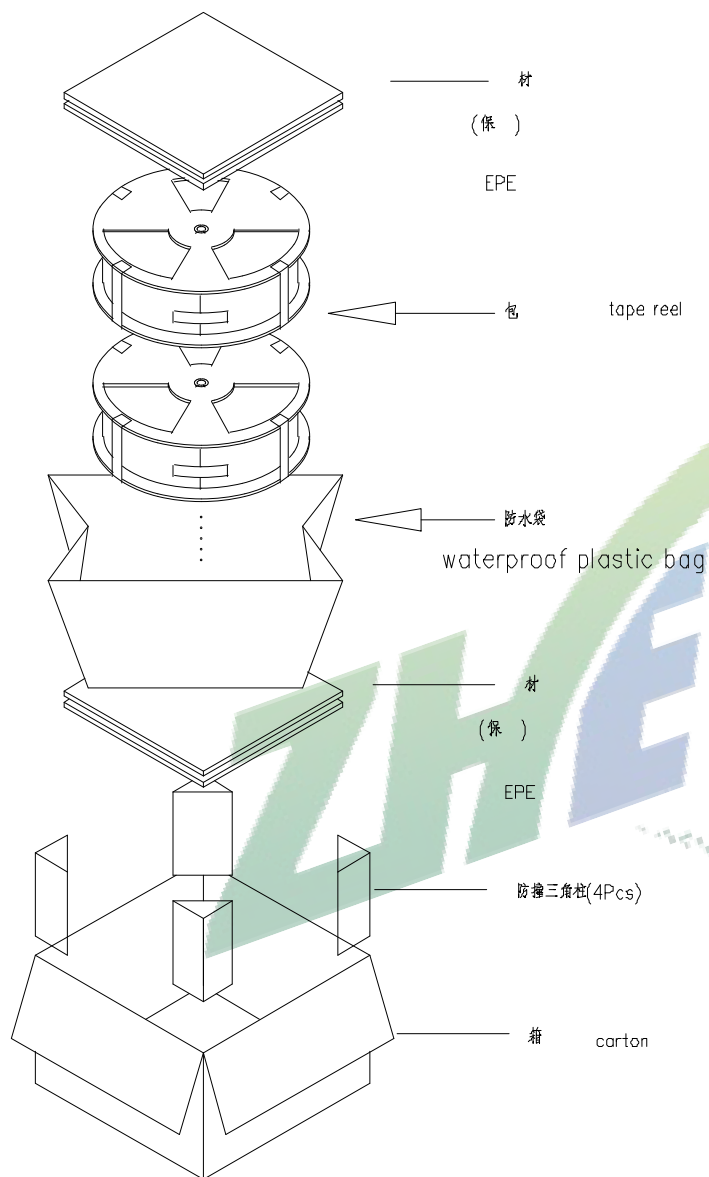

NOTE:

1. 每包量及每箱箱量如左下表格

Packing q'ty of each reel & carton as below table shown.

2. 以上覆下包包熔包

Use cover tape to cover and hot melt machine to seal up.

3. 每箱放2珍珠棉

Every carton use 2pcs EPE.

4. 品的卷放入箱并以封口

Put reels in the carton and use

adhesive tape to seal up.



振端精密科技(深圳)有限公司
Zhenduan precision technology (Shenzhen) Co., Ltd

TOLERANCE: X.X ±0.30 X.XX ±0.20 X.XXX ±0.10 X.XX ±0.10 X.X ±0.05 X.X ±0.05	DRAWN BY :	DATE :	PART NAME:	
	刘志强	2015.08.18	TYPE-C16PIN立式贴板H9.3-10.5	
UNIT: mm [inch] SCALE: 1:1 SIZE: A4	CHECKED BY :	DATE :	PART NO.	SEE TABLE
	李毅	2015.08.18	MOLD NO.	
	APPROVED BY :	DATE :	DRAW NO.:	ZDJNKJ00001615
	张少辉	2015.08.18	SHEET NO.	1 OF 1