

- NOTES:
- ELECTRICAL:
 - CONTACT CURRENT RATING 5.0A FOR VBUS AND GND(PINS A4 A9 B4 B9)
 - INSULATION RESISTANCE: 100 MEGAOHMS MIN. AT 250VDC.
 - DIELECTRIC WITHSTANDING VOLTAGE: 100VAC MIN.
 - LOW CONTACT RESISTANCE: INITIAL 40mΩ MAX. AFTER 50mΩ MAX.
 - MECHANICAL CHARACTERISTICS:
 - INSERTION FORCE: 5N~20N.
 - EXTRACTION FORCE: 8N~20N FORM 1 TO 1000CYCLES. 6~20N FORM 1001 TO 10000CYCLES.
 - DURABILITY: 10,000 MATING CYCLES
 - OPERATING TEMPERATURE: -55°C TO +85°C
 - COPLANARITY: 0.08MAX.
 - PART NUMBER INFORMATION:

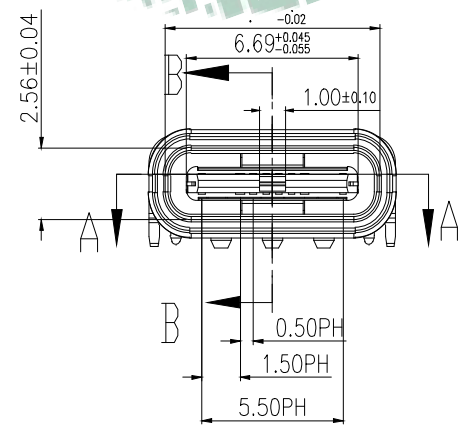

zhenduan 振端精密科技 (深圳) 有限公司
Zhenduan precision technology (Shenzhen) Co., Ltd

TOLERANCE: X.X ±0.30 X.XX ±0.20 X.XXX ±0.10 X.XX ±0.10 X.X ±0.05 X.X ±0.05	DRAWN BY :	DATE :	PART NAME:	
	刘志强	2015.08.18	TYPE-C 16P防水四脚插板L6.45	
UNIT: mm [inch] SCALE: 1:1 SIZE: A4	CHECKED BY :	DATE :	PART NO.	SEE TABLE
	李毅	2015.08.18	MOLD NO.	
	APPROVED BY :	DATE :	DRAW NO.:	ZDHS1600FS084
	张少辉	2015.08.18	SHEET NO.	1 OF 1

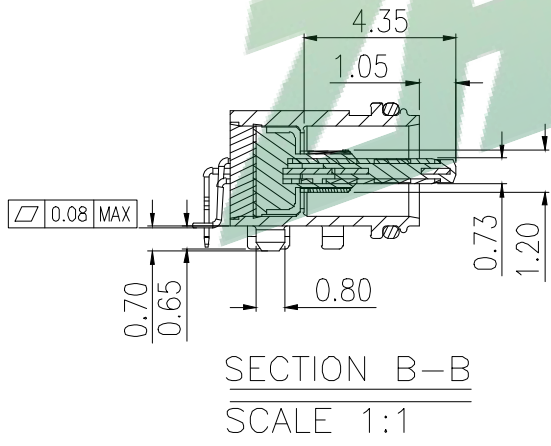
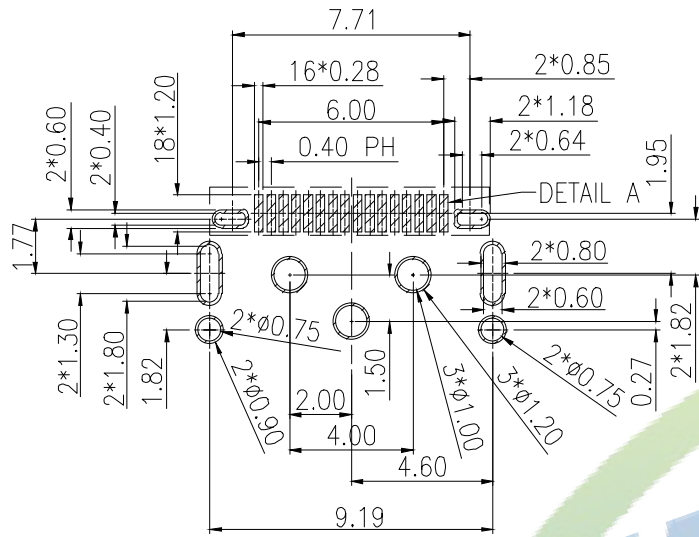

RECOMMENDED PCB LAYOUT

GENERAL TOLERANCE ± 0.05

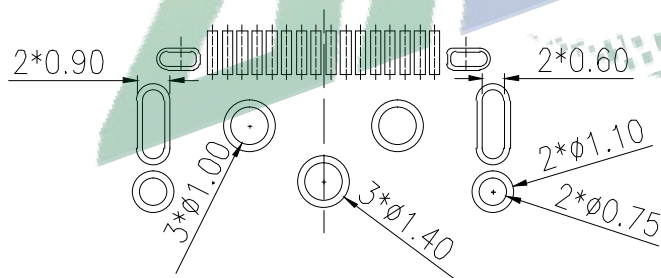

RECOMMENDED STENCIL LAYOUT

TOLERANCE ± 0.05

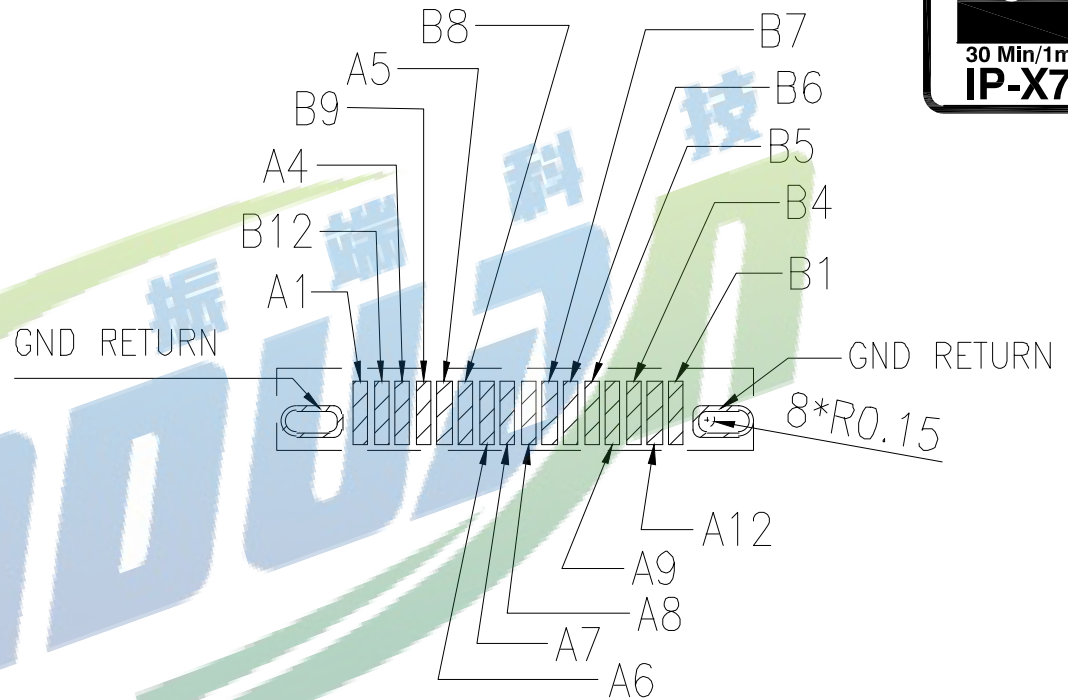

DETAIL A

振端精密科技 (深圳) 有限公司 Zhenduan precision technology (Shenzhen) Co., Ltd			
TOLERANCE: X.XX ± 0.30 X.XXX ± 0.20 X.XXX ± 0.10 X.X ± 0.10 X.X ± 0.05 X.X ± 0.05	DRAWN BY : 刘志强	DATE : 2015.08.18	PART NAME: TYPE-C 16P防水四脚插板L6.45
UNIT: mm [inch] SCALE: 1:1 SIZE: A4	CHECKED BY: 李文毅	DATE : 2015.08.18	PART NO. SEE TABLE MOLD NO.
	APPROVED BY: 张少辉	DATE : 2015.08.18	DRAW NO.: ZDHS1600FS084 SHEET NO. 1 OF 1