

NOTE:

- 1.MATERIAL SPECIFICATION:
  - 1.HOUSING:HIGH TEMPERATURE RESISTANT PLASTIC,UL94 V-0.
  - 2.CONTACTS:COPPER ALLOY
  - 3.MID PLATE: STAINLESS STEEL
  - 4.FRONT SHELL: STAINLESS STEEL
- 2.PLATING SPECIFICATION:
  - 2-1.CONTACTS:  
Ni 50u" MIN. UNDER PLATED OVER ALL.  
Au PLATED ON THE FUNCTIONAL AREA OF CONTACT.  
(GOLD PLATING THICKNESS FOLLOW THE P/N)  
PLATING SPECIFICATIONS OF THE SOLDER AREA FOLLOW THE P/N
  - 2-2.FRONT SHELL:  
Ni 30u" MIN. UNDER PLATED OVER ALL.
  - 2-3.MID PLATE:  
CLEAR ONLY
- 3.MECHANICAL PERFORMANCE,
  - 3-1.INSERTION FORCE: 0.5~2.0kgf.
  - 3-2.REMOVAL FORCE: 0.8kgf~2.0kgf.
  - 3-3.DURABILITY: 10000 CYCLES.
- 4.ELECTRICAL PERFORMANCE,
  - 4-1. CURRENT RATING:5.0A  
VOLTAGE RATING:5.0V
  - 4-2. LLCR:  
VBUS & GND PINS AND OTHER PINS: 40mΩ/PIN MAX.  
SHIELD: 50mΩ/MAX.  
LLCR MAX. CHANGE OF ALL PINS: 10mΩ.
  - 4-3.INSULATION RESISTANCE: 100MΩ MIN
  - 4-4.DIELECTRIC WITHSTAND VOLTAGE,AC 100V FOR 1 MINUTE.
5. ENVIRONMENTAL PERFORMANCE:  
OPERATING TEMPERATURE: -25°C~+85°C.
- 6.IR REFLOW:  
THE PEAK TEMPERATURE ON THE BOARD SHALL  
BE MAINTAINED FOR 10 SECONDS AT 260°C.

**ZDX** 深圳市兆达鑫科技有限公司  
Shenzhen Zhao Xin Technology Co., Ltd.

TOLERANCE: X.XX ±0.30 X.XXX ±0.20 X.XXXX ±0.10 X.XXXX ±0.05 X.XXXX ±0.02 X.XXXX ±0.01	DRAWN BY : 刘志强	DATE : 2015.08.18	PART NAME: TYPE-C16P四脚前插后贴H6.5
UNIT: mm [inch] SCALE:1:1 SIZE: A4	CHECKED BY: 李毅	DATE : 2015.08.18	PART NO. SEE TABLE MOLD NO.
	APPROVED BY: 张少辉	DATE : 2015.08.18	DRAW NO: ZDJNKJ00001623 SHEET NO. 1 OF 1

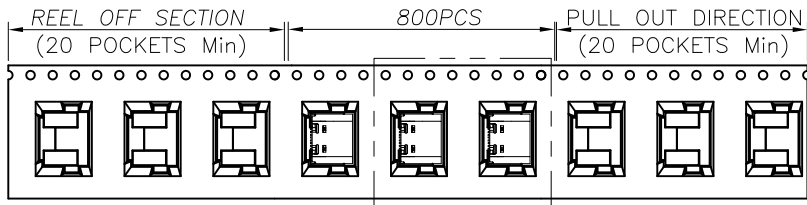

SEE DETAIL X

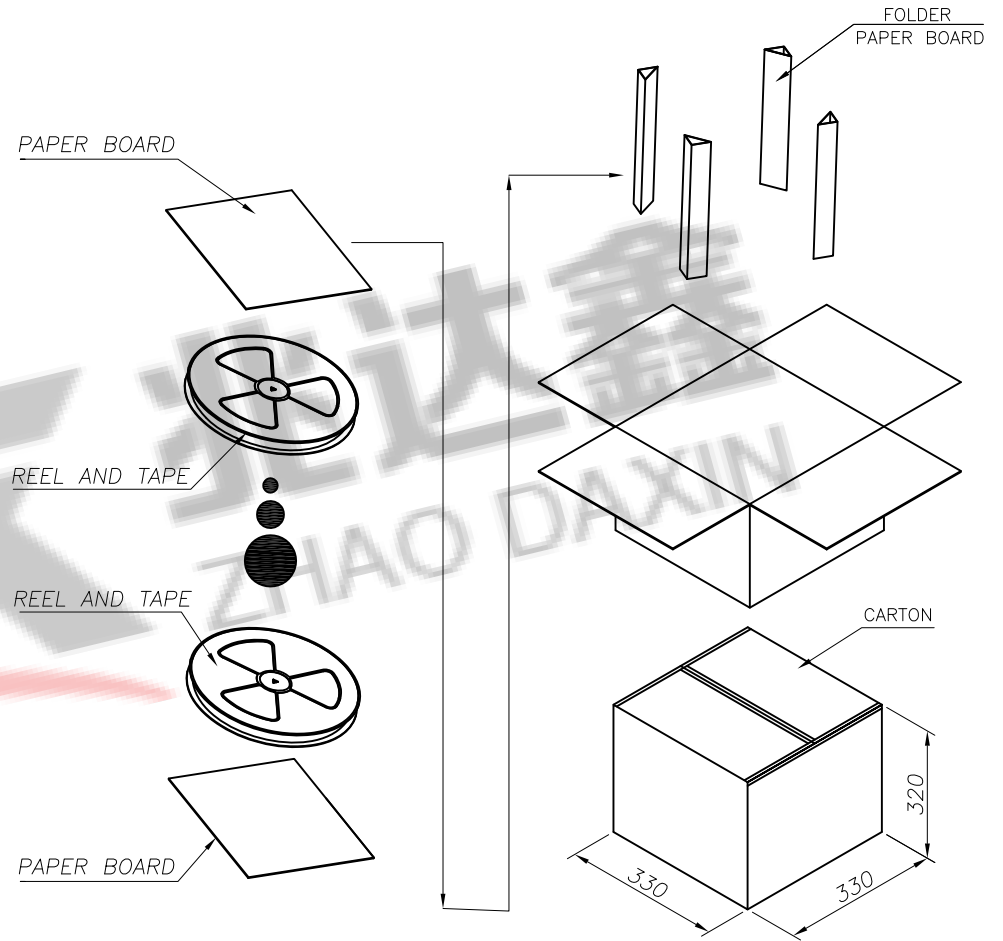
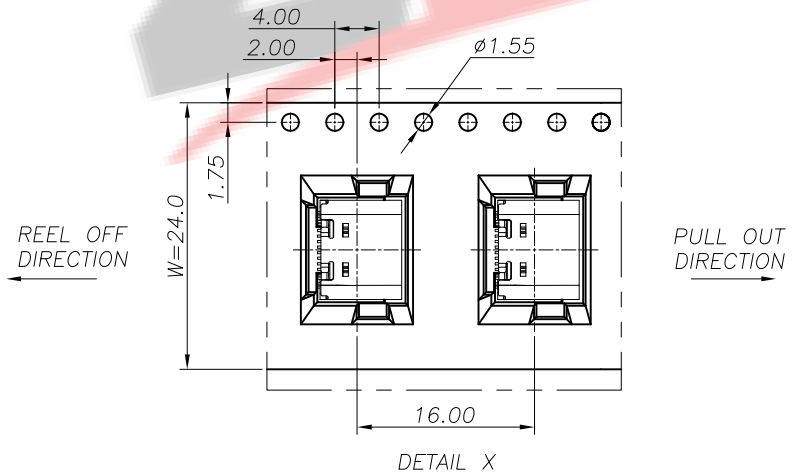
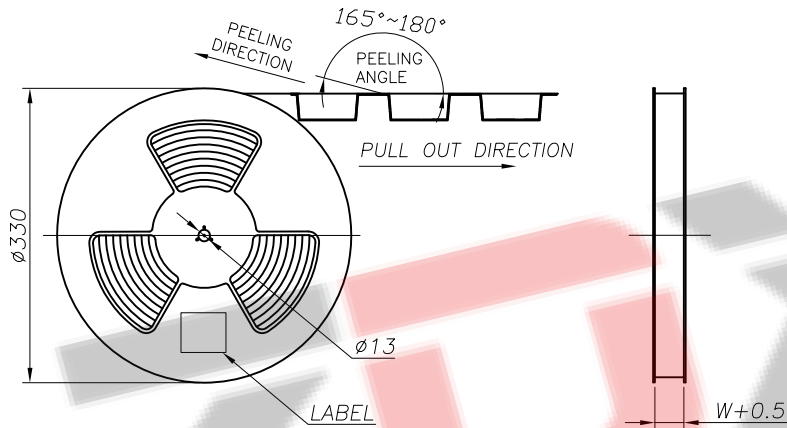

	REEL	CARTON
CONNECTOR (PCS)	800	8000

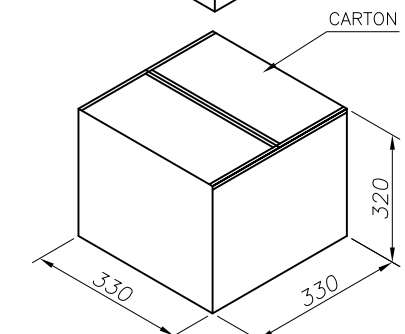

**ZDX** 深圳市兆达鑫科技有限公司  
Shenzhen Zhao Xin Technology Co., Ltd.

TOLERANCE: X.XX ±0.30 X.XXX ±0.20 X.XXX ±0.10 X.X ±0.10 X.X ±0.05	DRAWN BY : 刘志强	DATE : 2015.08.18	PART NAME: TYPE-C16P四脚前插后贴H6.5
 UNIT: mm [inch] SCALE: 1:1 SIZE: A4	CHECKED BY: 李毅	DATE : 2015.08.18	PART NO. SEE TABLE
	APPROVED BY: 张少辉	DATE : 2015.08.18	MOLD NO.
			DRAW NO: ZDJNKJ00001623
			SHEET NO. 1 OF 1