

- NOTES:
- 1.MATERIAL:
MOLDING: LCP UL94 V-0
CONTACT: COPPER ALLOY.
GOLD PLATED Min ON CONTACT AREA, 100u"
Min TIN (LEAD FREE) ON SOLDER AREA,
SHELL: SUS304-H, T=0.30±0.03mm
50u" NICKEL PLATING OVER ALL.
SHILD: SUS304-H, T=0.12±0.03mm
 - 2.MECHANICAL:
INSERTION: 5~20N.
EXTRACTION: 8~20N AFTER TEST.
DURABILITY: 10000 CYCLES
 - 3.ELECTRICAL:
CURRENT: 5A FOR VBUS;
1.25A FOR GND PIN.
0.25A FOR OTHER.
VOLTAGE: 20 V MAX
WITHSTANDING VOLTAGE: 100V AC R.M.S.
CONTACT RESISTANCE: 40mΩ MAX.
INSULATION RESISTANCE: 100MΩ MIN.
 - 4.ENVIRONMENTAL
TEMPERATURE RANGE -25°C ~ +85°C

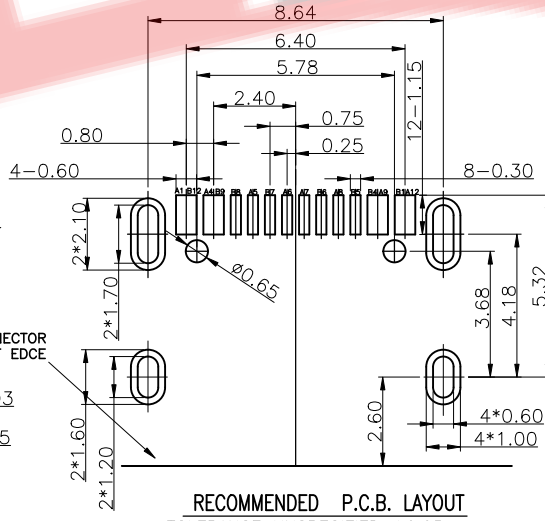
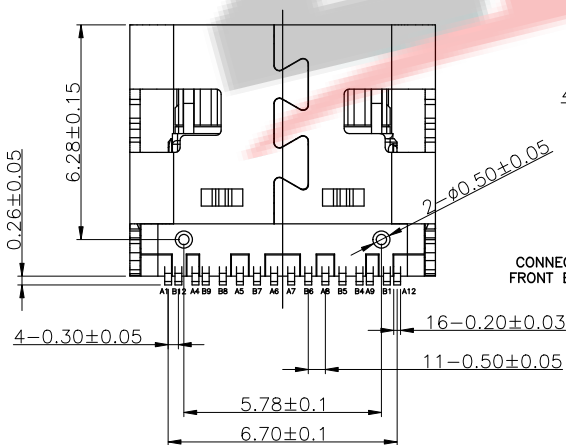
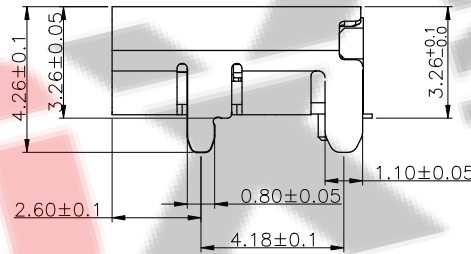
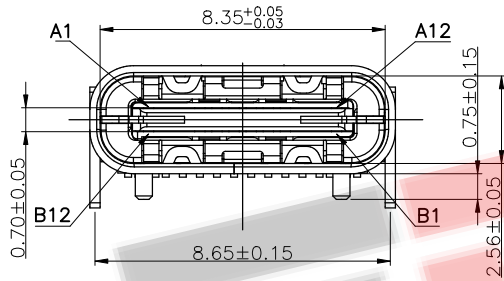

RECOMMENDED P.C.B. LAYOUT
TOLERANCE UNSPECIFIED ±0.05mm

A1	GND	B12	GND
A4	VBUS	B9	VBUS
A5	CC1	B8	SBU2
A6	DP1	B7	DN2
A7	DN1	B6	DP2
A8	SBU1	B5	CC2
A9	VBUS	B4	VBUS
A12	GND	B1	GND
PIN	SIGNAL NAME	PIN	SIGNAL NAME

USCX-16FX-XXMX-01

- 1-G.P
- 2-RoHS
- 3-REACH
- 4-HF/无卤

- B-半金镀层 1u"
- D-半金镀层 5u"
- F-半金镀层 15u"
- H-半金镀层 30u"

- 1-带锡包胶
- 2-PCBA
- N-可焊接
- S-雾锡
- T-亮锡
- A-全
- K-黑色
- N-本色



深圳市兆达鑫科技有限公司
Shenzhen Zhao Xin Technology Co., Ltd.

TOLERANCE: X.XX ±0.30 X.XXX ±0.20 X.XXX ±0.10 X.X ±0.10 X.X ±0.05 X.X ±0.05	DRAWN BY :	DATE :	PART NAME:	
	刘志强	2015.08.18	TYPE-C16P母座四脚插板H7.35	
UNIT: mm [inch] SCALE: 1:1 SIZE: A4	CHECKED BY :	DATE :	PART NO.	SEE TABLE
	李文毅	2015.08.18	MOLD NO.	
APPROVED BY : 张少辉	DATE :	DATE :	DRAW NO.:	ZDX00000001624
	2015.08.18	2015.08.18	SHEET NO.:	1 OF 1

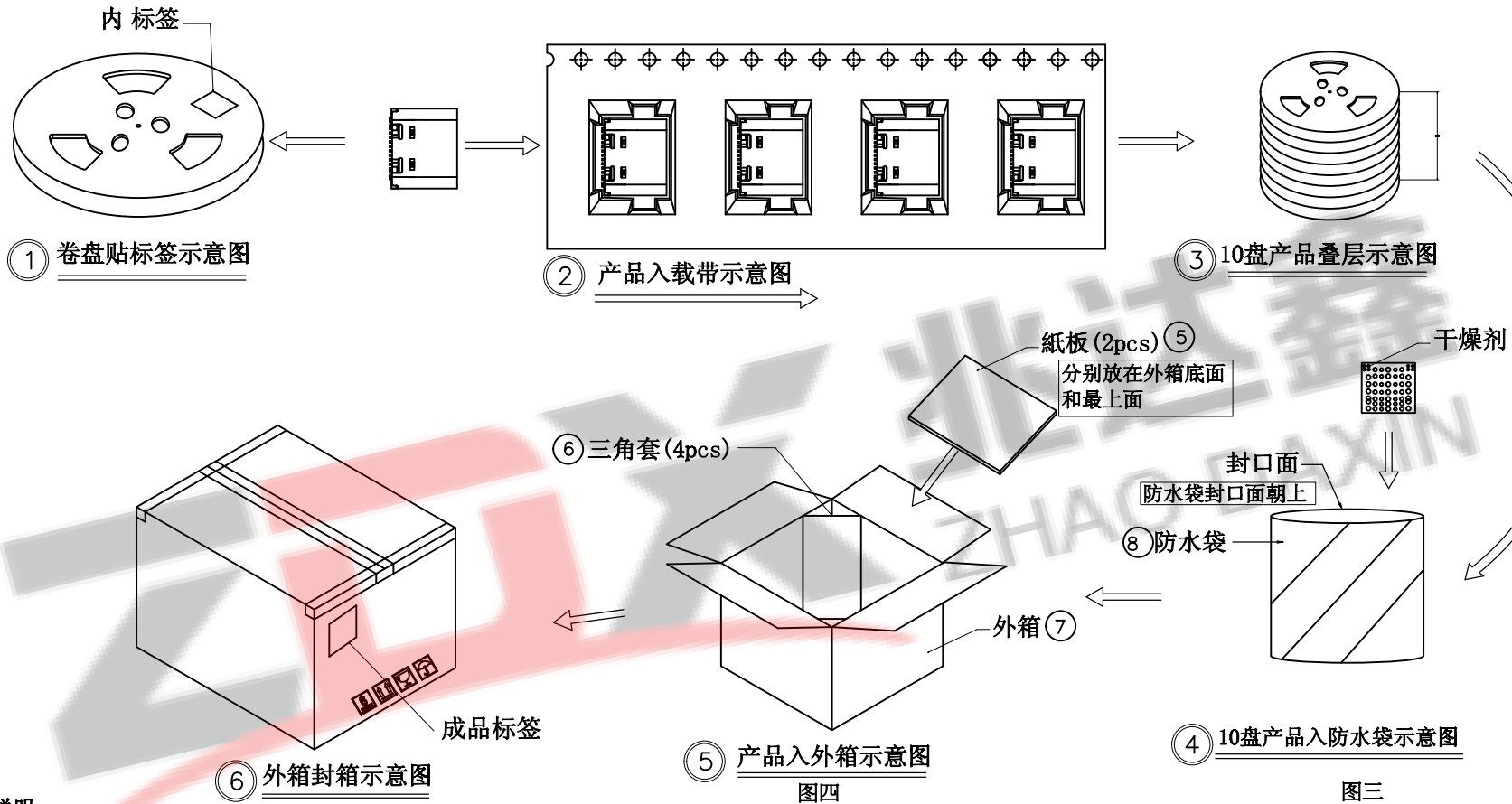

包装说明:

1. 将检验好的成品;SMT朝下放入载带底部;每卷装1000PCS产品,10000PCS/箱;具体如图一所示
2. 将包装好的产品;每盘必需贴上内标签;具体如图二所示
3. 将贴好内标签的产品每10盘叠一层装入防水袋中并加一包干燥剂;装好后将防水袋封好;具体如图三图四所示
4. 先将1pcs平卡放入纸箱底部;然后将装好产品的防水袋装入纸箱中;防水袋热熔封口,封口面需朝上;并将4PCS三角套分别装入4个角;如图五所示
5. 装好后将1pcs平卡放入纸箱最上面并封好纸箱及贴好相关标签;具体如图六所示;
(产品包装的标签,如客户有要求,请按客户要求包装出货)
6. 载带前面留30PCS空格,后面留20PCS空格
7. COVER与CARRY剥离力:50-125g,速度:300mm/分钟左右,剥离角度:165°-180°

深圳市兆达鑫科技有限公司 Shenzhen Zhao Xin Technology Co., Ltd.			
TOLERANCE: X.X ±0.30 X.XX ±0.20 X.XXX ±0.10 X.° ±10° .X° ±5°	DRAWN BY : 刘志强	DATE : 2015.08.18	PART NAME: TYPE-C16P母座四脚插板H7.35
UNIT: mm [inch] SCALE: 1:1 SIZE: A4	CHECKED BY: 李文毅	DATE : 2015.08.18	PART NO. SEE TABLE MOLD NO.
	APPROVED BY: 张少辉	DATE : 2015.08.18	DRAW NO: ZDX00000001624 SHEET NO. 1 OF 1