

SECTION A-A'

备注:

1. 产品规格:

- 1-1. 插入力: 35N MAX.
- 1-2. 拔出力: 10N MIN. INITIAL 8-20N AFTER
- 1-3. 额定电流: 1.0A
- 1-4. 额定电压: 30V
- 1-5. 耐久性: 10000 CYCLES MIN.
- 1-6. 耐电压: 100V AC MIN.
- 1-7. 接触阻抗: 30mΩ MAX. INITIAL; 40mΩ MAX AFTER
- 1-8. 绝缘电阻: 100MΩ MIN
- 1-9. 工作温度: -30° TO +80°

2. 材质:

- 2.1 胶芯: LCP UL94V-0
- 2.2 端子: C2680R-H, 镍底, 镀金1μ"
- 2.3 外壳: SUS201/301, 表面镀雾锡/镀镍

3. 重点尺寸标识"▲"符号

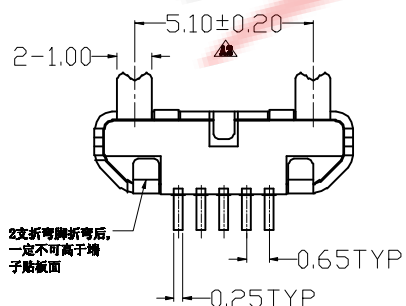

2支折弯脚折弯后, 一定不可高于端子贴板面

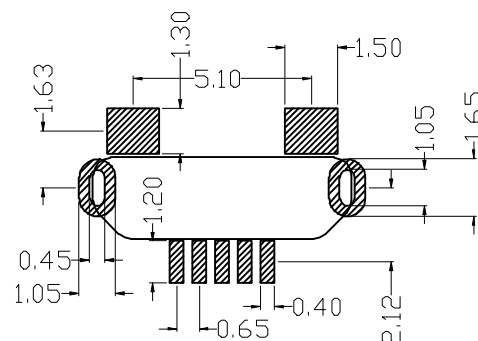

RECOMMENDED PCB LAYOUT
TOLERANCE: ±0.05

深圳市兆达鑫科技有限公司 Shenzhen Zhao Xin Technology Co., Ltd.			
TOLERANCE: X.XX ±0.30 X.XXX ±0.20 X.XXX ±0.10 X.X ±0.10 X.X ±0.05	DRAWN BY : 刘志强	DATE : 2015.08.18	PART NAME: MCSP母座立式贴板直边
UNIT: mm [inch] SCALE: 1:1 SIZE: A4	CHECKED BY: 李毅	DATE : 2015.08.18	PART NO. SEE TABLE MOLD NO.
	APPROVED BY: 张少辉	DATE : 2015.08.18	DRAW NO: ZDXMICROM30051 SHEET NO. 1 OF 1