

RECOMMENDE.P.C.B LAYOUT(TOP VIEW)
EFAULT YOLERANCE:±0.05

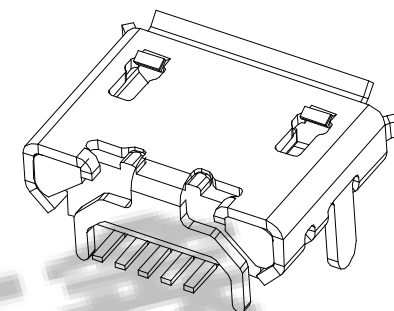

备注:

1. 产品规格:

- 1-1. 插入力:35N MAX.
- 1-2. 拔出力:10N MIN. INITIAL 8-20N AFTER
- 1-3. 额定电流:1.0A
- 1-4. 额定电压:30V
- 1-5. 耐久性:10000 CYCLES MIN.
- 1-6. 耐电压:100V AC MIN.
- 1-7. 接触阻抗:30mΩ MAX. INITIAL;40mΩ MAX AFTER
- 1-8. 绝缘电阻:100MΩ MIN
- 1-9. 工作温度:-30° TO +80°

2. 材质:

- 2.1胶芯: LCP UL94V-0
- 2.2端子: C2680R-H, 镍底, 镀金1μ"
- 2.3外壳: SUS201/301, 表面镀雾锡/镀镍

3. 重点尺寸标识"▲"符号

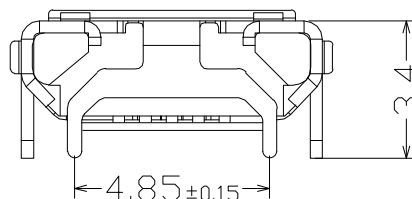
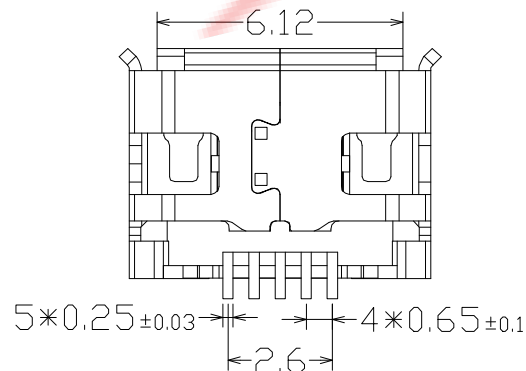
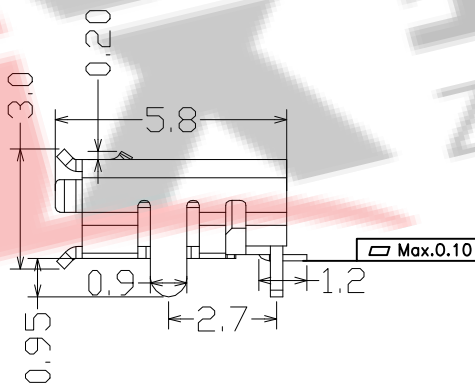
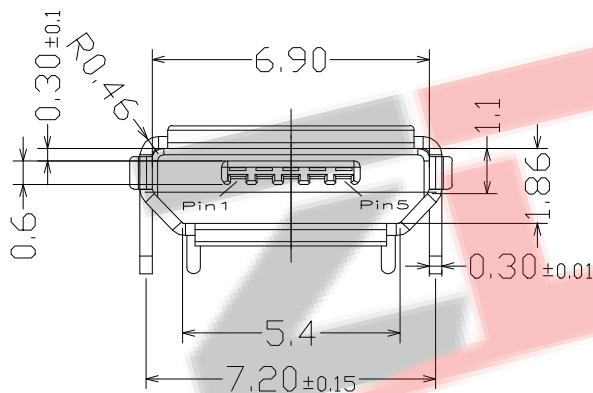

深圳市兆达鑫科技有限公司 Shenzhen Zhao Xin Technology Co., Ltd.			
TOLERANCE: XXX ±0.30 XX XX ±0.20 X XXX ±0.10 X.X ±0.10 X.XX ±0.05	DRAWN BY : 刘志强	DATE : 2015.08.18	PART NAME: MC5P母座小牛角4.85卷边
UNIT: mm [inch] SCALE:1:1 SIZE: A4	CHECKED BY: 李毅	DATE : 2015.08.18	PART NO. SEE TABLE MOLD NO.
APPROVED BY: 张少辉	DATE : 2015.08.18	DRAW NO.: ZDXMICROM30068	SHEET NO.: 1 OF 1