

备注 (NOTE):

1. 材质:

- 1-1. 塑胶: PA9T 黑色UL94V-0, 符合环保.
- 1-2. 端子: C2680-H T, 镀半金雾锡1U".
- 1-3. 外壳: SUS201-1/2H 镀镍48H, 符合SGS环保.

2. 尺寸标注事项:

- 2-1. 图示有标注"▲"记号者为重点尺寸.
- 2-2. 图示所有标注"\*"尺寸为首样全检尺寸.
- 2-3. 图示所有标注"Cpk"尺寸为Cpk检验尺寸.

3. 电气特性:

- 3-1. 接触区: 接触电阻40mΩ Max, 允许10mΩ变化量. 测试条件: 20mv, 100mA下测量.
- 3-2. 接触电流: 3A VBUS引脚; 1.25A用于GND引脚; 其他引脚为0.25A.
- 3-3. 额定电压: 30V.
- 3-4. 耐电电压: 100VR. M. S.
- 3-5. 绝缘电阻: 至少100兆欧.

4. 机械性能:

- 4-1. 插入力: 0.51-2.04Kg, 拔出力: 0.51-2.04Kg
- 4-2. 插拔次数: 10000次.
- 5. 工作环境: -20°C to +85°C.

6. 测试要求:

- 6-1. 吃锡测试: 95%, 盐雾测试: 24HR MIN.

7. 品质要求事项:

- 7-1. 产品表面不能刮伤, 划伤压痕, 缺胶, 歪PIN, 起气泡.
- 7-2. 镀层要均匀, 不能有发黑发白及露铜现象.

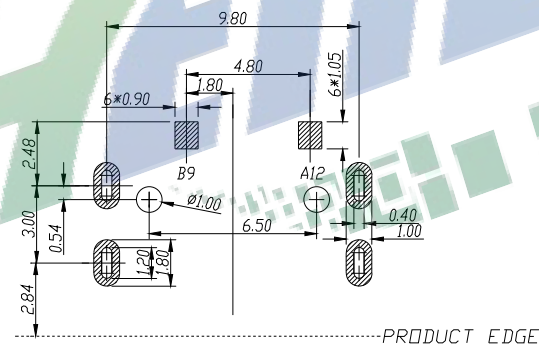
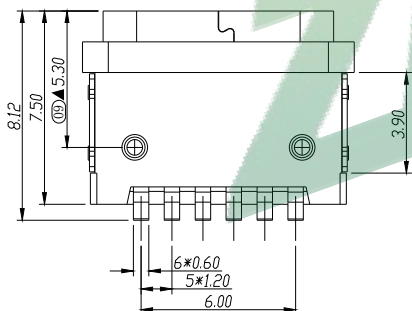
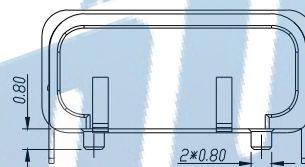
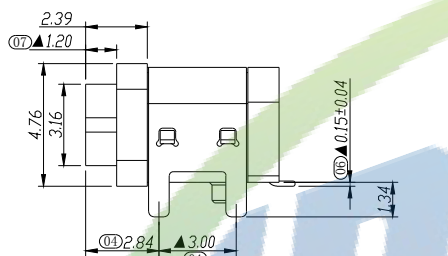
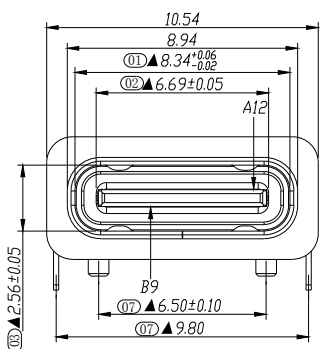

RECOMMENDED PCB LAYOUT (TOP VIEW)  
THICKNESS 0.8±0.10MM; DEFAULT TOLERANCE: ±0.05

A12	A11	A10	A9	A8	A7	A6	A5	A4	A3	A2	A1
GND											
								VBUS			
B1	B2	B3	B4	B5	B6	B7	B8	B9	B10	B11	B12

**振端精密科技 (深圳) 有限公司**  
Zhenduan precision technology (Shenzhen) Co., Ltd

TOLERANCE: X:XX ±0.30 X:XXX ±0.20 X:XXX ±0.10 X:XX ±10° X:XX ±8° X:XX ±5°	DRAWN BY : 刘志强	DATE : 2015.08.18	PART NAME: TYPE-C2P防水四脚前插后贴L7.5
UNIT: mm [inch] SCALE: 1:1 SIZE: A4	CHECKED BY: 李毅	DATE : 2015.08.18	PART NO. SEE TABLE
	APPROVED BY: 张少辉	DATE : 2015.08.18	MOLD NO.
			DRAW NO: ZDHS0600FS203
			SHEET NO. 1 OF 1