

防水圈图示

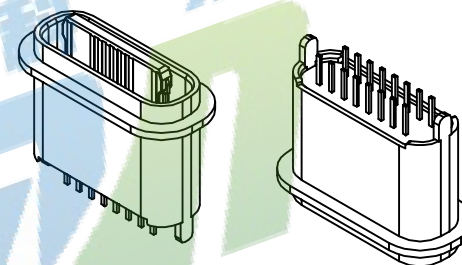
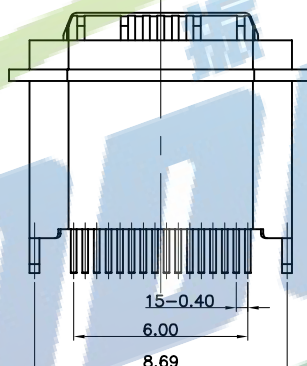
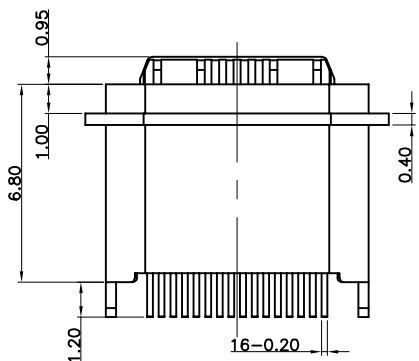

NOTES:

SPECIFICATION:

- CURRENT RATING: 3.0 A
- VOLTAGE RATING: 3.0 V
- VBUS & GND PINS AND OTHER PINS: 40mΩ/PIN MAX  
SHIELD: 50mΩ/MAX  
LLCR MAX. CHANGE OF ALL PINS: 10Ωm
- INSULATION RESISTANCE: 100MΩ MIN
- DIELECTRIC WITHSTAND VOLTAGE, AC 100V FOR 1MIN
- INSERTION FORCE: 0.5~2.0kgf
- UNMATING FORCE: 0.8-2.0kgf
- DURABILITY: 10000 CYCLES
- OPERATING TEMPERATURE: -35°C~+85°C
- THE PEAK TEMPERATURE ON THE BOARD SHALL BE MAINTAINED FOR 10 SECONDS AT 260°C
- WATERPROOF: IP-X7.

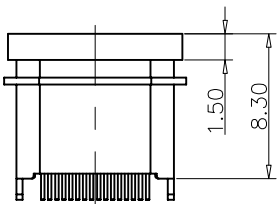
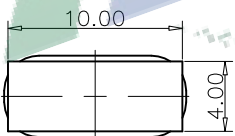
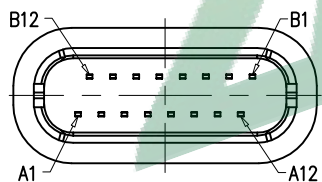

装前塞示意图

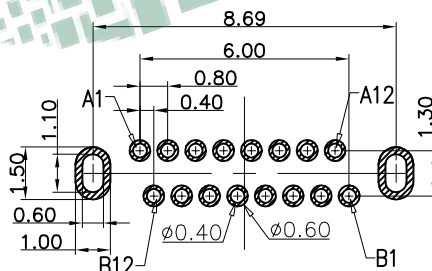

RECOMMEND P.C.B LAYOUT  
TOLERANCE UNSPECIFIED ±0.05mm

USB TYPE C PIN ASSIGNMENTS

PIN NUMBER	SIGNAL NAME	PIN NUMBER	SIGNAL NAME
A1	GND	B12	GND
A4	VBUS	B9	VBUS
A5	CC1	B8	SBU2
A6	DP1	B7	DN2
A7	DN1	B6	DP2
A8	SBU1	B5	CC2
A9	VBUS	B4	VBUS
A12	GND	B1	GND

**振端精密科技 (深圳) 有限公司**  
Zhenduan precision technology (Shenzhen) Co., Ltd

TOLERANCE: X.XX ±0.30 X.XXX ±0.20 X.XXX ±0.10 X.X ±10° X.X ±5°	DRAWN BY :	DATE :	PART NAME: TYPE-C16P防水立插 H6.8粉末冶金舌头外露0.95	
	刘志强	2015.08.18	PART NO.	SEE TABLE
UNIT: mm [inch] SCALE: 1:1 SIZE: A4	CHECKED BY :	DATE :	MOLD NO.	
	李毅	2015.08.18	DRAW NO.:	ZDHS0600FS257
APPROVED BY :		DATE :	SHEET NO. 1 OF 1	
张少辉		2015.08.18		