

装前塞示意图

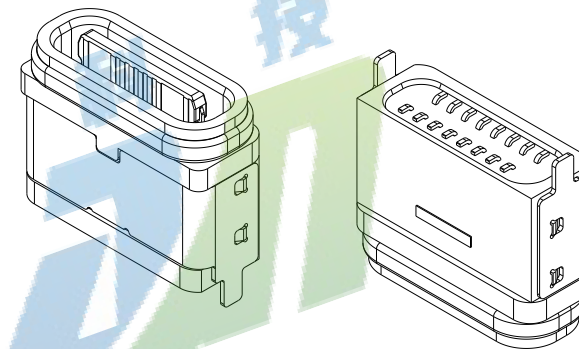
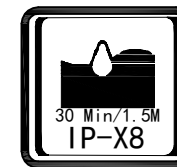

NOTES:

SPECIFICATION:

1. CURRENT RATING: 3.0 A
2. VOLTAGE RATING: 3.0 V
3. VBUS & GND PINS AND OTHER PINS: 40mΩ/PIN MAX
SHIELD: 50mΩ/MAX
LLCR MAX. CHANGE OF ALL PINS: 10Ωm
4. INSULATION RESISTANCE: 100MΩ MIN
5. DIELECTRIC WITHSTAND VOLTAGE, AC 100V FOR 1MIN
6. INSERTION FORCE: 0.5~2.0kgf
7. UNMATING FORCE: 0.8~2.0kgf
8. DURABILITY: 10000 CYCLES
9. OPERATING TEMPERATURE: -35°C~+85°C
10. THE PEAK TEMPERATURE ON THE BOARD SHALL BE MAINTAINED FOR 10 SECONDS AT 260°C
11. WATERPROOF: IP-X7.

USB TYPE C PIN ASSIGNMENTS

PIN NUMBER	SIGNAL NAME	PIN NUMBER	SIGNAL NAME
A1	GND	B12	GND
A4	VBUS	B9	VBUS
A5	CC1	B8	SBU2
A6	DP1	B7	DN2
A7	DN1	B6	DP2
A8	SBU1	B5	CC2
A9	VBUS	B4	VBUS
A12	GND	B1	GND

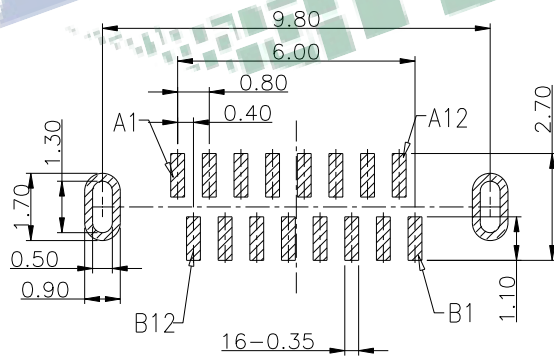

RECOMMEND P.C.B LAYOUT
TOLERANCE UNSPECIFIED ±0.05mm

振端精密科技 (深圳) 有限公司
Zhenduan precision technology (Shenzhen) Co., Ltd

TOLERANCE: X.XX ±0.30 X.XXX ±0.20 X.XXX ±0.10 X.XX ±0.05 X.X ±0.02 X.X ±0.01	DRAWN BY : 刘志强	DATE : 2015.08.18	PART NAME: TYPE-C16P防水两脚 立贴全塑H7.45	
	CHECKED BY: 李毅	DATE : 2015.08.18	PART NO.	SEE TABLE
UNIT: mm [inch] SCALE: 1:1 SIZE: A4	APPROVED BY: 张少辉	DATE : 2015.08.18	DRAW NO: ZDHS0600FS273	SHEET NO. 1 OF 1