

密封圈

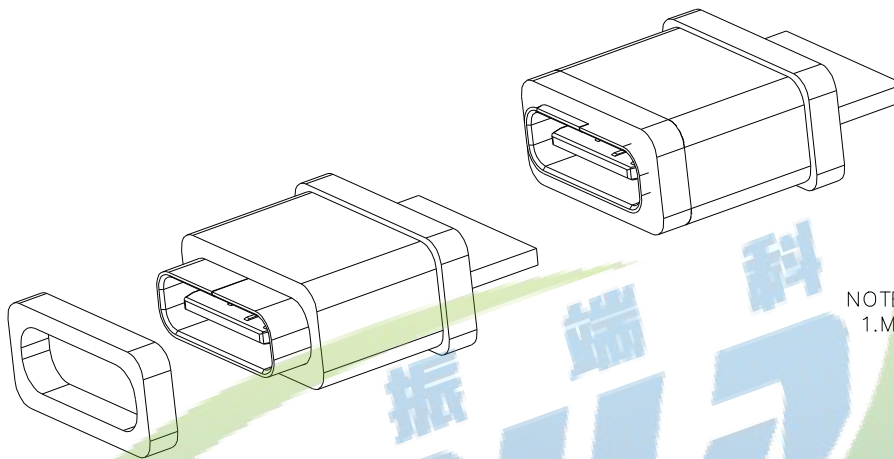
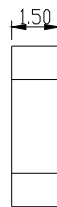
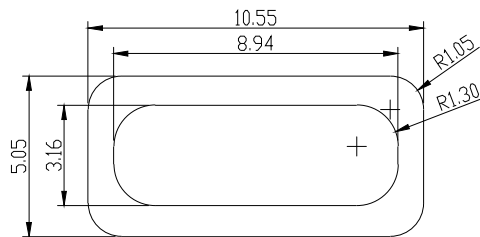

NOTES:

1.MATERIAL:

MOLDING: LCP UL94 V-0
 CONTACT: COPPER ALLOY.
 GOLD PLATED Min ON CONTACT AREA,100u"
 Min TIN (LEAD FREE) ON SOLDER AREA,
 SHELL: SUS304-H,T=0.30±0.03mm
 50u" NICKEL PLATING OVER ALL.

2.MECHANICAL:

INSERTION: 5~20N.
 EXTRACTION: 8~20N AFTER TEST.
 DURABILITY: 10000 CYCLES

3.ELECTRICAL:

CURRENT: 3A FOR VBUS;
 1.25A FOR GND PIN.
 0.25A FOR OTHER.
 VOLTAGE: 20 V MAX
 WITHSTANDING VOLTAGE: 100V AC R.M.S.
 CONTACT RESISTANCE: 40mΩ MAX.
 INSULATION RESISTANCE: 100MΩ MIN.

4.ENVIRONMENTAL

TEMPERATURE RANGE -25°C ~ +85°C

振端精密科技 (深圳) 有限公司 Zhenduan precision technology (Shenzhen) Co., Ltd			
TOLERANCE: X.XX ±0.30 X.XXX ±0.20 X.XXX ±0.10 X.X ±0.10 X.X ±0.05 X.X ±0.05	DRAWN BY : 刘志强	DATE : 2015.08.18	PART NAME: TYPE-C16P防水 焊线式带四个焊点H10.0
UNIT: mm [inch] SCALE: 1:1 SIZE: A4	CHECKED BY: 李毅	DATE : 2015.08.18	PART NO. SEE TABLE MOLD NO.
	APPROVED BY: 张少辉	DATE : 2015.08.18	DRAW NO: ZDHS0600FS253 SHEET NO. 1 OF 1